

High Efficiency Power Amplifier Module (OEM Version)

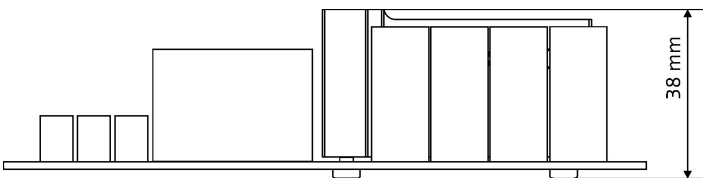
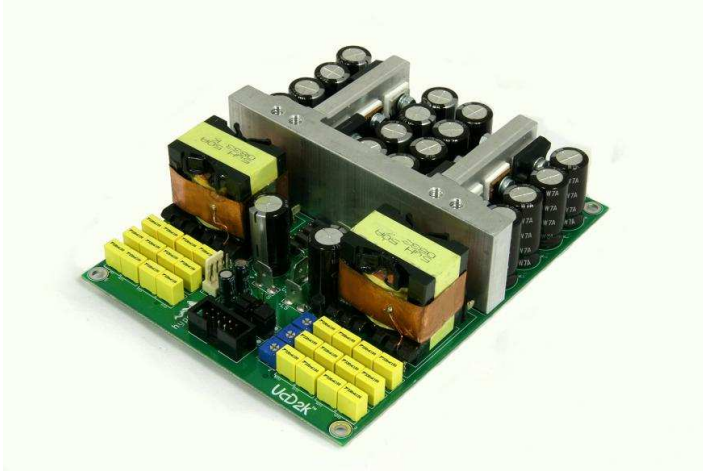

Highlights

- Flat, fully load-independent frequency response
- Low output impedance
- Low, frequency-independent THD
- Very low noise
- Fully passive loop control

Features

- Runs on unregulated +/- rails
- Pop-free start and stop control
- Differential audio input
- On-board clipping detection
- DC-fault detection
- Overcurrent and overvoltage protection
- Dimensions: 141 x 108 x 38mm
- Weight: 550g

Applications

- Public Address systems
- Active loudspeakers

Description

The UcD2kOEM amplifier module is a self-contained high-performance class D amplifier intended for audio applications requiring reliable, high power amplification and high audio quality. Chief distinguishing features are flat frequency response irrespective of load impedance, nearly frequency-independent distortion behaviour and very low radiated and conducted EMI. Control is based on a phase-shift controlled self-oscillating loop taking feedback only at the speaker output.

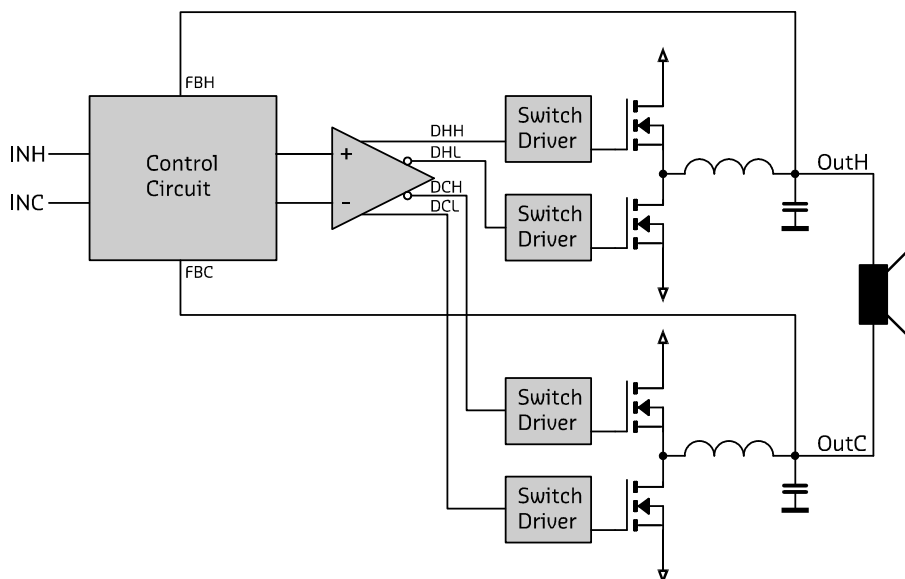

Contents

Contents.....	2
1 Performance data.....	2
2 Absolute maximum ratings.....	2
3 Recommended Operating Conditions.....	3
4 Connections.....	3
5 Typical Performance Graphs.....	8
6 Dimensions.....	10

1 Performance data

Power supply = +/-72V, Load=4Ω, MBW=40kHz, unless otherwise noted

Item	Symbol	Min	Typ	Max	Unit	Notes
Output Power	P_R	1600			W	8Ω, THD=1%
		2500			W	4Ω, THD=1%
		2000	-	-	W	2Ω, THD=1%
Distortion	THD+N	-	0.02	0.05	%	20Hz<f<20kHz ¹⁾ Pout<P _R /2
		-	-	0.03	%	20Hz<f<20kHz Pout=1W
Output noise	U_N	-	30μ	35μ	V	Unwtd, 20Hz-20kHz
Output Impedance	Z_{OUT}	-	-	10m	Ω	f<1kHz
		-	-	50m	Ω	f<20kHz
Power Bandwidth	PBW		20-35k		Hz	²⁾
Frequency Response		10	-	50k	Hz	+0/-3dB. All loads.
Voltage Gain	A_V	33.5	34	34.5	dB	
Required input level for 2500W/4Ω/THD=1%			2.25		V	Appropriate supply voltage level assumed
Supply Ripple Rejection	PSRR		65		dB	Either rail, all frequencies.
Efficiency	η		92		%	Full power
Idle Losses	P_0		35		W	
Standby Current	I_{STBY}		10m		A	
Current Limit			50		A	Hiccup mode after limiting for 40ms

Note 1: At higher audio frequencies there are not enough harmonics left in the audio band to make a meaningful THD measurement. High frequency distortion is therefore determined using a 18.5kHz+19.5kHz 1:1 two-tone IMD test.

Note 2: Dielectric losses in the output capacitor limit long term (>30s) full-power bandwidth to 15kHz.

2 Absolute maximum ratings

Correct operation at these limits is not guaranteed. Operation beyond these limits may result in irreversible damage

Item	Symbol	Rating	Unit	Notes
Power supply voltage	V_B	+/-100	V	Unit shuts down when either rail exceeds 98V
Driver supply voltage	V_{DR}	+16	V	Referenced to $-V_B$
Peak output current	$I_{OUT,P}$	52	A	Unit current-limits at 50A
Input voltage	V_{IN}	+/-12	V	Either input referenced to ground
Air Temperature	T_{AMB}	65	°C	
Heat-sink temperature	T_{SINK}	95 ¹⁾	°C	User to select heat sink to insure this condition under most adverse use case

Note 1: Unit will shut down when T_{SINK} exceeds 95° due to thermal protection

3 Recommended Operating Conditions

Item	Symbol	Min	Typ	Max	Unit	Notes
Power supply voltage	V_B	50 ¹⁾	+/- 90	98 ²⁾	V	
Driver supply voltage	V_{DR}	+13	+15		V	Referenced to $-V_B$
Load impedance	Z_{LOAD}	1			Ω	
Source impedance	Z_{SRC}			7k	Ω	Differential. Corresponds to 3dB noise increase.
Effective power supply storage capacitance	C_{SUP}	20m ³⁾			F	Per rail, per attached amplifier. 2 Ω load presumed.

Note 1: Reduced performance.

Note 2: Unit shuts down when either rail exceeds 98V.

Note 2: The effective power supply storage capacitance of Hypex SMPS is already in excess of 20mF. Do not add supplementary capacitance.

4 Connections

4.1 Connection diagram

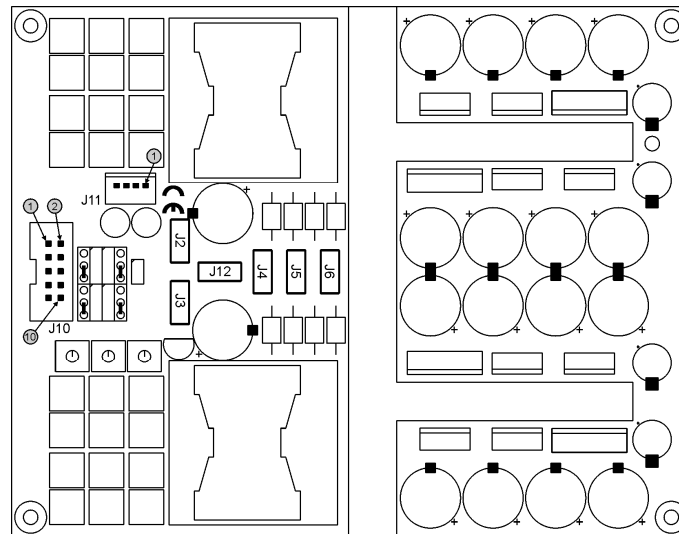

Figure 1: Connector pinning Ucd2k

4.2 J10/J11: Auxiliary connection

J10 Connector type: Standard 2.54mm boxheader.

J11 Connector type: 4-pin MOLEX® KK® series, part number 22-27-2041.

Pin (J10)	Pin (J11)	Function
7	4	Non inverting Audio Input
3	3	GND
8	2	Inverting Audio Input
6	1	ON/OFF control
4		AMP_RDY
5		Clip indicator
9		Over Current Monitor
10		DC Protect
1		+12V ¹⁾
2		-12V ¹⁾

Note 1: This auxiliary supply only supplies the on-board buffer opamp and can be omitted when this opamp is bypassed.

4.3 J3: Loudspeaker output (hot)

Connector type: 6,3x0,8 FASTON® tab.

4.4 J2: Loudspeaker output (cold)

Connector type: 6,3x0,8 FASTON® tab.

This connection is NOT connected to ground due to the full bridge topology.

4.5 J4: Positive power supply connection, +VB

Connector type: 6,3x0,8 FASTON® tab.

4.6 J5: Power supply ground connection, GND

Connector type: 6,3x0,8 FASTON® tab.

4.7 J6: Negative power supply connection, -VB

Connector type: 6,3x0,8 FASTON® tab.

4.8 J12: Driver supply connection (referenced to -V_B)

Connector type: 6,3x0,8 FASTON® tab.

4.9 Audio Input Characteristics

Item	Symbol	Min	Typ	Max	Unit	Notes
Input Impedance	Z _{IN}		100k		Ω	Either input to ground
CM Rejection Ratio	CMRR		45		dB	All frequencies

4.10 Clipping detection Characteristics

The UcD2kOEM has an integrated output clipping detection which will pull pin 5(J10) low in case of such an event.

Item	Min	Typ	Max	Unit	Notes
Voltage on pin 5(J10), clipping			1	V	Internal open collector ¹⁾

Note 1: Is meant to be externally pulled to a positive voltage by means of a resistor. Open collector maximum output current: 100mA. Maximum collector voltage: 65V.

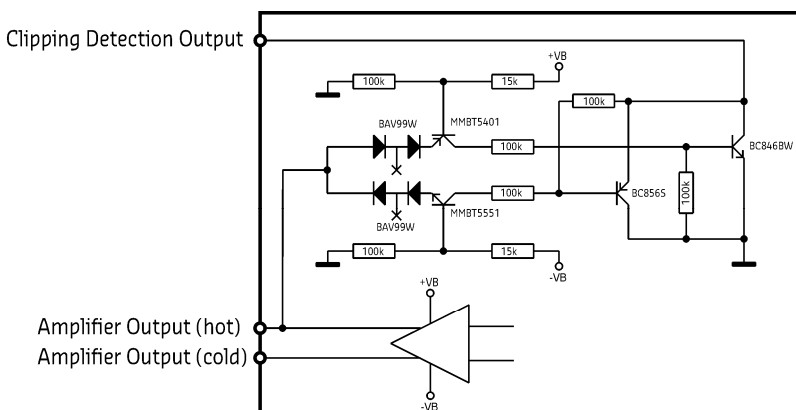

Figure 2: Clipping Detection Output interface.

4.11 Control DC-Error Signalling Characteristics

The UcD2kOEM has an integrated DC-error detection which will pull pin 10(J10) low in case of such an event. It is recommended to sense this fault condition and to interrupt both power supply lines in such an event.

Item	Min	Typ	Max	Unit	Notes
Voltage on pin 10(J10), DC-error			1	V	Internal open collector ¹⁾

Note 1: Must be pulled to a positive voltage by means of an external resistor. Open collector maximum output current: 100mA. Maximum collector voltage: 65V.

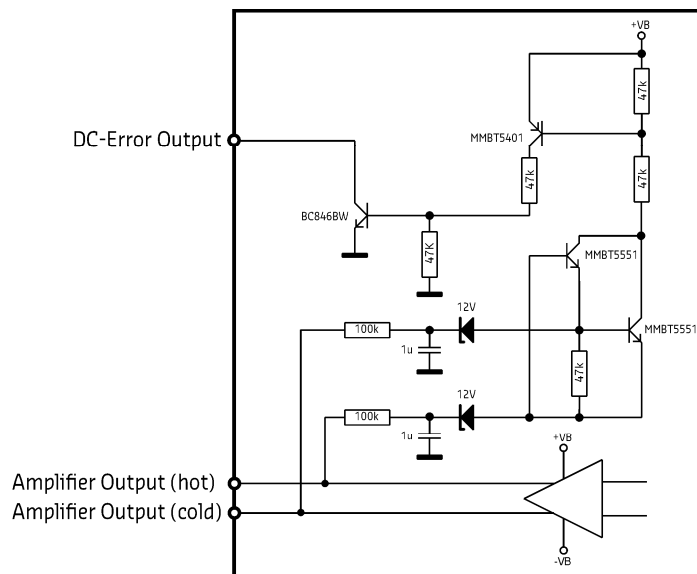

Figure 3: DC-Error Output interface.

4.12 Amplifier ON/OFF Characteristics

The UcD2kOEM is enabled by pulling either pin 6(J10) or pin 1(J11) low. Leaving these pins floating will put the amplifier in standby.

Item	Min	Typ	Max	Unit	Notes
Voltage on pin pin 6(J10)/ pin 1(J11), left floating			6,5	V	Internally pulled up 1)

Note 1: Must be pulled low by means of an open collector.

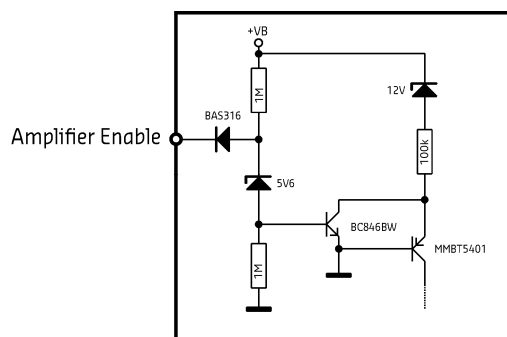

Figure 4: Amplifier On/Off interface.

4.13 Amplifier Ready Characteristics

The UcD2kOEM has an integrated Amplifier Ready condition which will pull pin 4(J10) high to indicate that the amplifier shut itself down due to an error. This error can be either an overvoltage event or a shorted output

Item	Min	Typ	Max	Unit	Notes
Voltage on pin 4(J10), error			5,6	V	Internally pulled up

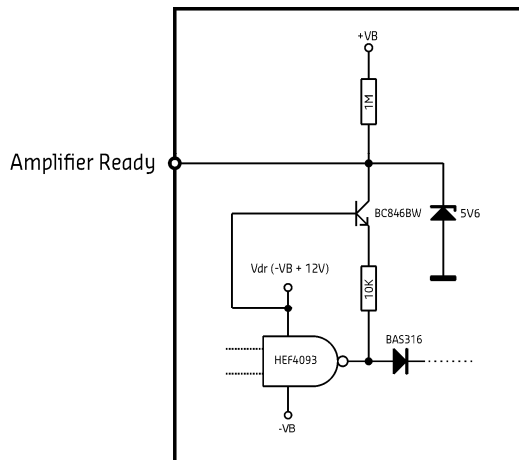

Figure 5: Amplifier Ready Output interface.

4.14 Current Limiter Monitoring

The UcD2kOEM has a current limiter monitoring output which is pulled low in the event of an output current limiting situation. This output is not latched/delayed and is therefore only active when the limiter is active.

Item	Min	Typ	Max	Unit	Notes
Voltage on pin 9 (J10), Current limiting	-0,7			V	Internally pulled up

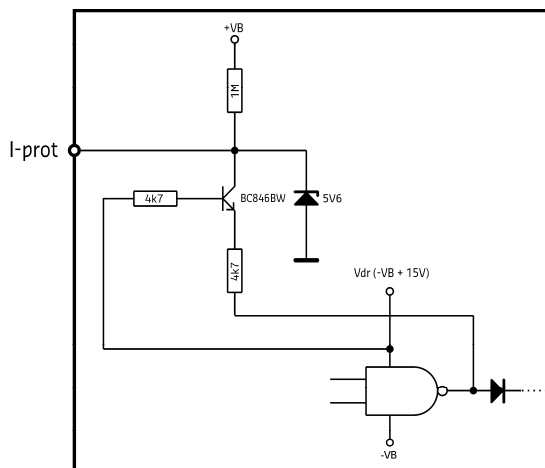
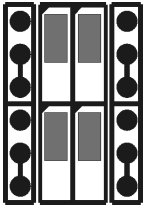

Figure 6: Current limiter monitoring.

4.15 Signal path characteristics



The UcD2kOEM enables the user to choose between two different ways of input signal routing. Standard jumper settings are set to use the on-board buffer op-amp (NE5532). In order to bypass the on-board buffer and AC-coupling capacitors all four jumpers (J21, J22, J23, J24) need to be set according to picture.

Note: Since the amplifier is now fully DC-coupled the user must ensure that the input signal is completely free of DC components.

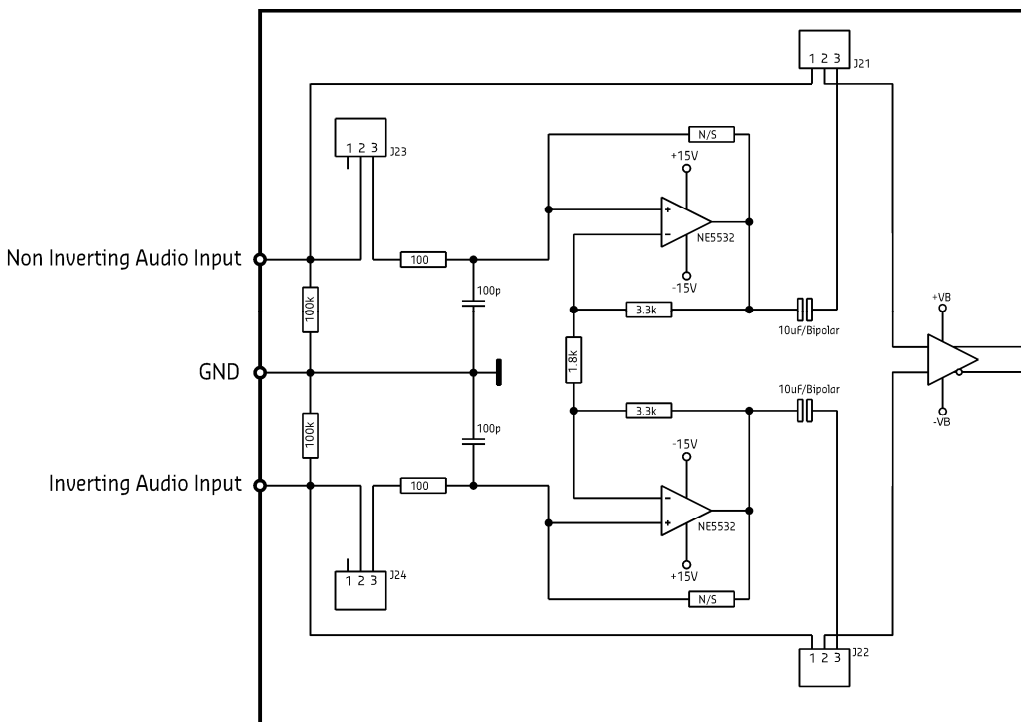

Figure 7: Audio Input Buffer interface.

4.16 Amplifier start-up delay

During initial power up the amplifier is disabled for approx. 1.5s regardless of the state of the enable pin. Once powered up there is no start or stop delay.

5 Typical Performance Graphs

5.1 THD vs. Power (1kHz, 2Ω)

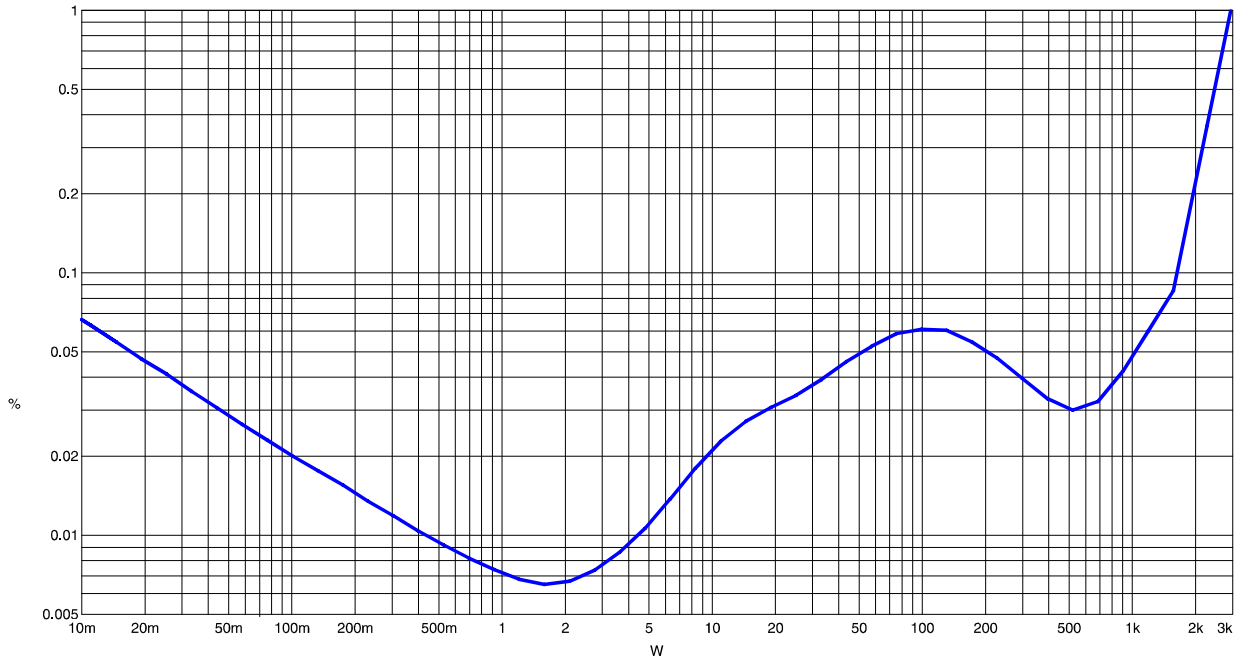

5.2 THD vs. Power (1kHz, 4Ω)

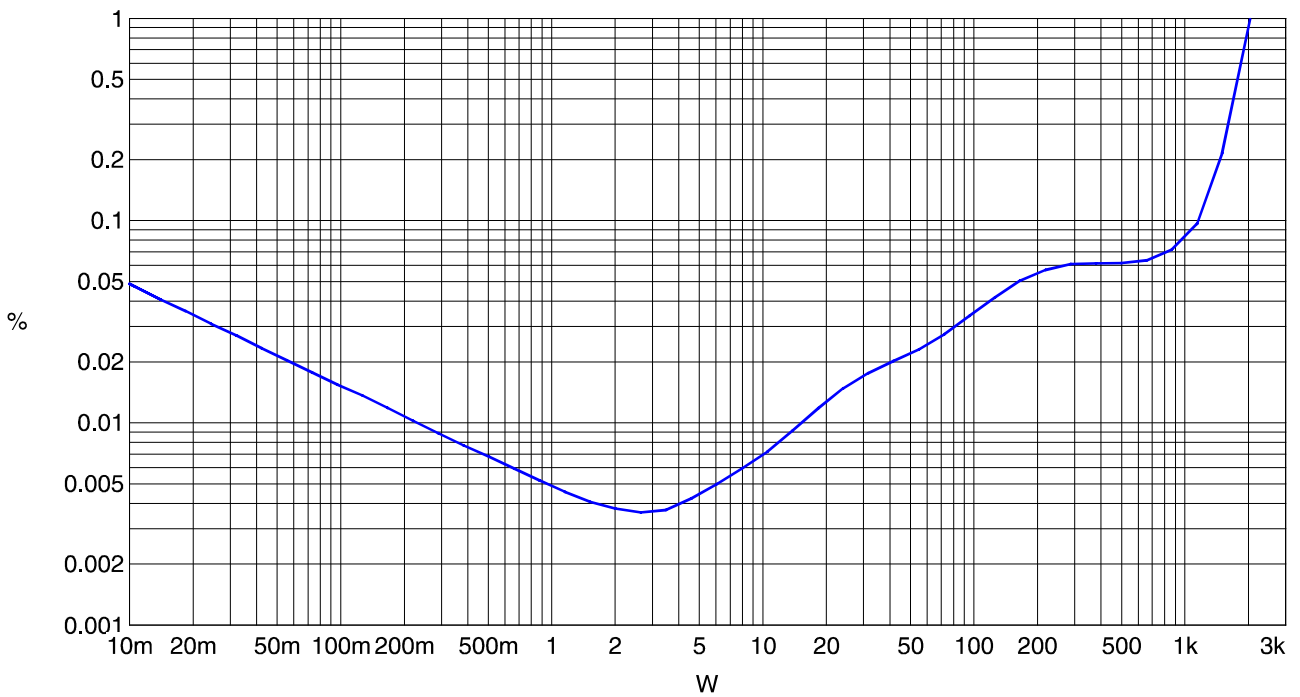

5.3 THD vs. Frequency (4Ω)

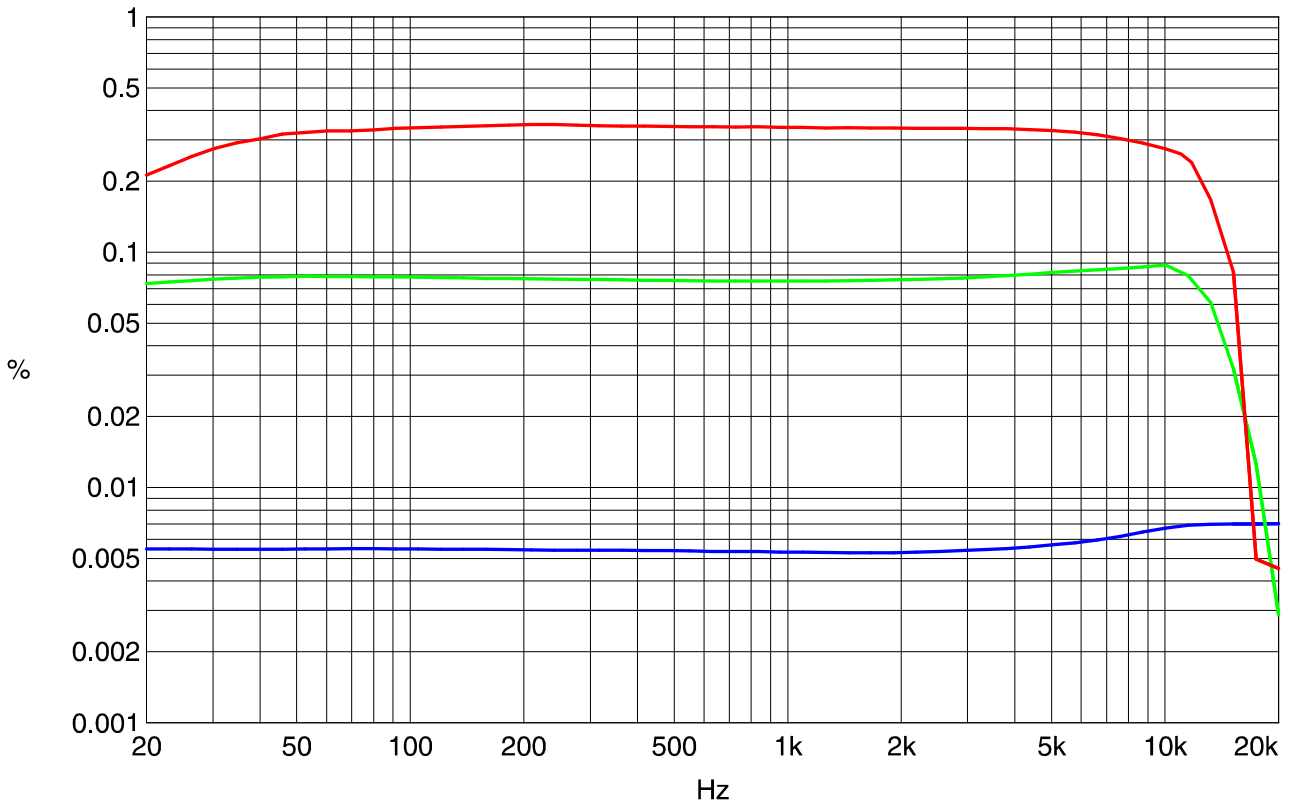

From top to bottom: 2kW, 500W, 5W

5.4 Frequency Response (2Ω, 4Ω and open circuit)

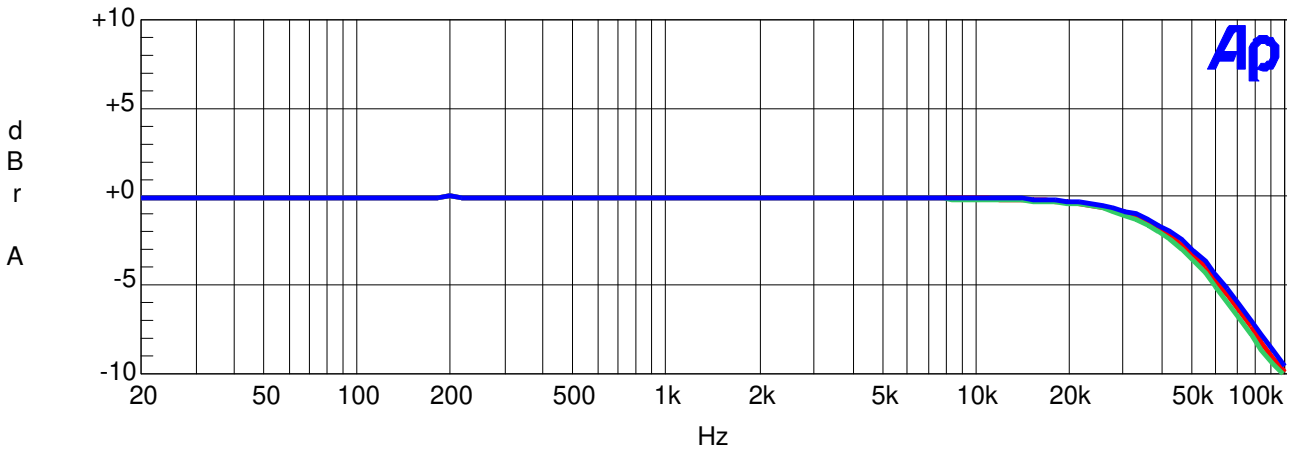

From top to bottom: open circuit, 4Ω, 2Ω

5.5 Output Impedance

tbd

5.6 19+20kHz IMD (10W, 4Ω)

tbd

6 Dimensions

Heatsink drill pattern. Top view.

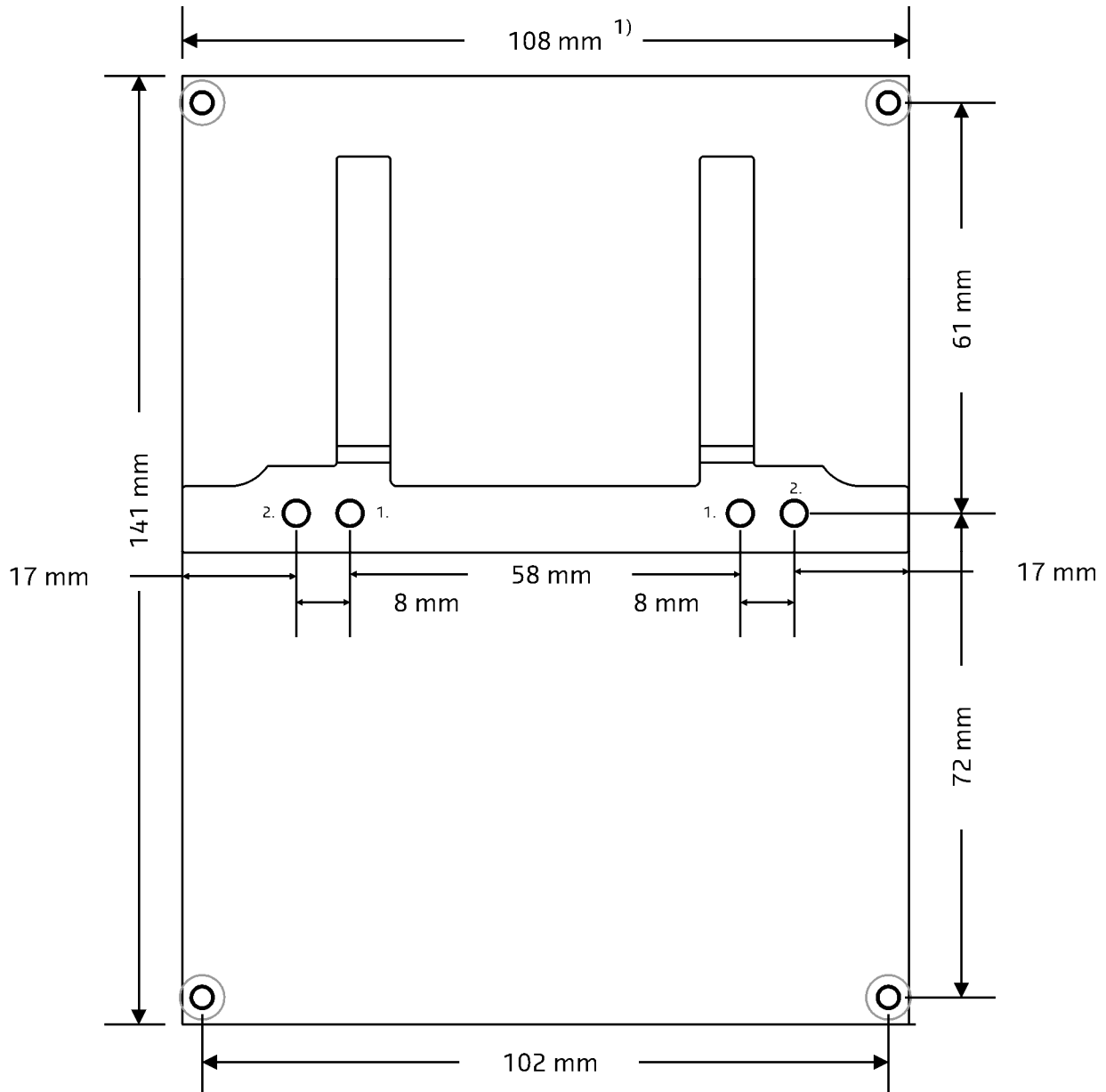

1. Metric M5
2. UNC 10-24

Note 1: UcD2k up to V3 is 110mm. V4 is changed to fit 4 pieces in 19" cases.

DISCLAIMER: This subassembly is designed for use in music reproduction equipment only. No representations are made as to fitness for other uses. Except where noted otherwise any specifications given pertain to this subassembly only. Responsibility for verifying the performance, safety, reliability and compliance with legal standards of end products using this subassembly falls to the manufacturer of said end product.

LIFE SUPPORT POLICY: Use of Hypex products in life support equipment or equipment whose failure can reasonably be expected to result in injury or death is not permitted except by explicit written consent from Hypex Electronics BV.

Document Revision	PCB Version	Description	Date
R1	UcD2kOEMV0.4	- Pre-production batch.	
R2	UcD2kOEMV1	- User selectable input signal routing. The input buffer and coupling caps can be bypassed for direct comparator driving. Default jumpers are set for AC-coupled input buffering. - Amp_Ready output added. - Clip detection output added. - UNC 10-24 heatsink mounting holes (2x) added. - Solder jumper 'on/off select' via J11/J10 removed*. - Solder jumpers 'J8 signal in'/'J10 signal' in removed*. * Both on/off and input signals are connected to J11 and J10.	
R3	UcD2kOEMV2	- Convenient header added for added optional Kelvin sensing. - Output connector silkscreen corrected. - Amplifier Ready circuit corrected. (functionality hasn't changed). - VDR/UVL modification applied.	03.03.2009
R4	UcD2kOEMV2	- Recommended VDR voltage added.	09.02.2010
R5	UcD2kOEMV2	- VDR UVLO value added.	31.05.2010
R6	UcD2kOEMV3	- Current Limit monitor function added.	12.10.2010
R7	UcD2kOEMV3	- Current Limit monitor added in "Connections" diagram	15.08.2011
R8	UcD2kOEMV4	- Recommended operation conditions updated - Dimensions updated to V4 hardware - Format changed	17.09.2012
R9	UcD2kOEMV4	- Correct designator in description for 4p signal connector - Removed Note about only prototyping purpose J11 - Description J10 now complete	12.04.2019